





# Chapter 9 Braking system

## Contents

Anti-lock brake system (ABS) - general information	2	Disc brake pads - renewal	3
Brake check	See Chapter 1	Drum brake shoes - renewal	6
Brake disc - inspection, removal and refitting	5	General information	1
Brake fluid level check	See Chapter 1	Handbrake assembly - check, removal and refitting	12
Brake hoses and lines - inspection and renewal	15	Handbrake - adjustment	11
Brake hydraulic system - bleeding	16	Handbrake cable(s) - renewal	10
Brake pedal - adjustment	13	Hydraulic brake servo - description, removal and refitting	9
Brake vacuum servo - check, removal and refitting	8	Master cylinder - removal and refitting	7
Disc brake caliper - removal, overhaul and refitting	4	Stop-light switch - check and adjustment	14

## Degrees of difficulty

<b>Easy</b> , suitable for novice with little experience 	<b>Fairly easy</b> , suitable for beginner with some experience 	<b>Fairly difficult</b> , suitable for competent DIY mechanic 	<b>Difficult</b> , suitable for experienced DIY mechanic 	<b>Very difficult</b> , suitable for expert DIY or professional 
---	--	--	---	--

## Specifications

### General

Brake fluid type ..... See Chapter 1

### Disc brakes

Minimum brake pad thickness ..... See Chapter 1

Brake disc minimum permissible thickness (wear limit)\*

Front

3-Series

Solid discs ..... 10.7 mm

Ventilated discs ..... 20.0 mm

5-Series

Solid discs ..... 10.0 mm

Ventilated discs ..... 20.0 mm

Rear

..... 8.0 mm

Brake disc minimum thickness after machining

Front

3-Series

Solid discs ..... 11.1 mm

Ventilated discs ..... 20.4 mm

5-Series

Solid discs ..... 10.4 mm

Ventilated discs ..... 20.4 mm

Rear

..... 8.4 mm

Parallelism (difference between any two measurements) ..... 0.02 mm

Maximum disc run-out ..... 0.2 mm

\* Refer to marks cast into the disc (they supersede information printed here)

### Brake pedal adjustments

Brake pedal/servo pushrod adjustment (A) (3-Series) ..... 125 mm

Brake pedal height (pedal-to-bulkhead distance)

3-Series

Left-hand-drive ..... 235 mm

Right-hand-drive ..... 273 mm

5-Series

..... 245 mm

Stop-light switch adjustment (dimension A - see text) ..... 5.0 mm to 6.0 mm

### Handbrake

Handbrake shoe lining minimum thickness ..... 1.5 mm

Handbrake lever travel ..... 5 to 8 clicks

## 9•2 Braking system

Torque wrench settings	Nm
Front disc brake caliper	
Caliper guide (mounting) bolts	30 to 35
Caliper bracket-to-strut housing bolts	
3-Series, E30	123
5-Series, E28 ("old-shape")	123
5-Series, E34 ("new-shape")	110
Rear disc brake caliper	
Caliper guide (mounting) bolts	30 to 35
Carrier-to-trailing arm bolts	67
Brake hose-to-caliper fitting	14 to 17
Master cylinder-to-brake servo nuts	
3-Series	24
5-Series	25 to 29
Brake servo mounting nuts	22 to 24
Hydraulic line-to-hydraulic brake servo threaded fittings - 5-Series, E28 ("old-shape")	31
Wheel bolts	See Chapter 1

### 1 General information

All 3-Series models, and 5-Series E28 ("old-shape") models, are equipped with front disc brakes and either rear drum or rear disc brakes. 5-Series E34 ("new-shape") models have disc brakes front and rear. Front and rear brakes are self-adjusting on all models. Some later models are equipped with an Anti-lock Braking System (ABS); this is described in Section 2.

#### Hydraulic system

The hydraulic system consists of two separate circuits. The master cylinder has separate reservoirs for the two circuits; in the event of a leak or failure in one hydraulic circuit, the other circuit will remain operative.

#### Brake servo

The vacuum brake servo, utilising engine manifold vacuum and atmospheric pressure to provide assistance to the hydraulically operated brakes, is mounted on the bulkhead in the engine compartment.

A hydraulic brake servo system is used on 5-Series E28 models. This system uses hydraulic pressure from the power steering pump to assist braking.

#### Handbrake

The handbrake operates the rear brakes, and is cable-operated via a lever mounted in the centre console. The handbrake assembly on rear drum brake models is part of the rear drum brake assembly, and is self-adjusting. On rear disc brake models, the handbrake uses a pair of brake shoes located inside the centre portion of the rear brake disc, and is manually-adjusted.

#### Brake pad wear warning system

The brake pad wear warning system is linked to a red warning light in the instrument

cluster, which comes on when the brake pads have worn down to the point at which they require renewal. DO NOT ignore this reminder. If you don't renew the pads shortly after the brake pad wear warning light comes on, the brake discs will be damaged.

On some models, the brake pad wear warning system also includes an early warning light that comes on only when the brake pedal is depressed, letting you know in advance that the pads need to be renewed.

The wear sensor is attached to the brake pads. The sensor is located at the left front wheel; on some models, there is another sensor at the right rear wheel. The wear sensor is part of a closed circuit. Once the pads wear down to the point at which they're flush with the sensor, the disc grinds away the side of the sensor facing the disc. Thus, the wire inside the sensor is broken, and the red light on the instrument panel comes on.

Always check the sensor(s) when renewing the pads. If you change the pads before the warning light comes on, the sensor(s) may still be good; once the light has come on, renew the sensor.

#### Service

After completing any operation involving dismantling of any part of the brake system, always test drive the vehicle to check for proper braking performance before resuming normal driving. When testing the brakes, try to select a clean, dry, road with no camber (ie as flat as possible) and with no other traffic. Conditions other than these can lead to inaccurate test results.

Test the brakes at various speeds with both light and heavy pedal pressure. The vehicle should stop evenly, without pulling to one side or the other. Avoid locking the brakes, because this slides the tyres and diminishes braking efficiency and control of the vehicle.

Tyres, vehicle load and wheel alignment are factors which also affect braking performance.

### 2 Anti-lock Braking system (ABS) - general information

The Anti-lock Braking System is designed to maintain vehicle control, directional stability and optimum deceleration under severe braking conditions on most road surfaces. It does so by monitoring the rotational speed of each wheel and controlling the brake line pressure to each wheel during braking. This prevents the wheels from locking up.

The ABS system has three main components - the wheel speed sensors, the electronic control unit, and the hydraulic control unit. The sensors - one at each wheel since 1985, but at both front wheels and one at the rear differential on earlier models - send a variable voltage signal to the control unit, which monitors these signals, compares them to its program information, and determines whether a wheel is about to lock up. When a wheel is about to lock up, the control unit signals the hydraulic unit to reduce hydraulic pressure (or not increase it further) at that wheel's brake caliper. Pressure modulation is handled by electrically-operated solenoid valves.

If a problem develops within the system, an "ABS" warning light will glow on the dashboard. Sometimes, a visual inspection of the ABS system can help you locate the problem. Carefully inspect the ABS wiring harness. Pay particularly close attention to the harness and connections near each wheel. Look for signs of chafing and other damage caused by incorrectly-routed wires. If a wheel sensor harness is damaged, the sensor should be renewed (the harness and sensor are integral).



**Warning: DO NOT try to repair an ABS wiring harness. The ABS system is sensitive to even the smallest changes in resistance. Repairing the harness could alter resistance values**

and cause the system to malfunction. If the ABS wiring harness is damaged in any way, it must be renewed.



**Caution:** Make sure the ignition is turned off before unplugging or re-making any electrical connections.

### Diagnosis and repair

If the dashboard warning light comes on and stays on while the vehicle is in operation, the ABS system requires attention. Although special electronic ABS diagnostic testing tools are necessary to properly diagnose the system, you can perform a few preliminary checks before taking the vehicle to a dealer service department.

- Check the brake fluid level in the reservoir.
- Verify that the electronic control unit connectors are securely connected.
- Check the electrical connectors at the hydraulic control unit.
- Check the fuses.
- Follow the wiring harness to each front and rear wheel, and verify that all connections are secure and that the wiring is undamaged.

If the above preliminary checks do not rectify the problem, the vehicle should be

diagnosed by a dealer service department. Due to the complex nature of this system, all actual repair work must be done by a dealer service department.

### 3 Disc brake pads - renewal



**Warning:** Disc brake pads must be renewed on both front wheels or both rear wheels at the same time - NEVER renew the pads on only one wheel. Also, the dust created by the brake system may contain asbestos, which is harmful to your health. Never blow it out with compressed air, and don't inhale any of it. An approved filtering mask should be worn when working on the brakes. Do not, under any circumstances, use petroleum-based solvents to clean brake parts. Use brake system cleaner only! When servicing the disc brakes, use only original-equipment or high-quality brand-name pads.



**Warning:** Brake fluid is poisonous. It is also an effective paint stripper. Refer to the warning at the start of Section 16.

**Note:** This procedure applies to both the front and rear disc brakes.

1 Remove the cap(s) from the brake fluid reservoir, and syphon off about two-thirds of the fluid from the reservoir. Failing to do this

could result in the reservoir overflowing when the caliper pistons are pressed back into their bores.

2 Loosen the wheel bolts, raise the front or rear of the vehicle and support it securely on axle stands.

3 Remove the front or rear wheels, as applicable. Work on one brake assembly at a time, using the assembled brake for reference if necessary.

4 Inspect the brake disc carefully as outlined in Section 5. If machining is necessary, follow the information in that Section to remove the disc, at which time the pads can be removed from the calipers as well.

5 Follow the accompanying photos, beginning with illustration 3.5a, for the pad removal procedure. Be sure to stay in order, and read the caption under each illustration.

**Note 1:** Different types of front calipers are used on 3 and 5-Series models. Illustrations 3.5a to 3.5e are for the front calipers on 3-Series models. Illustrations 3.5f to 3.5m are for the front calipers on 5-Series models. There's no photo sequence for rear calipers; although slightly different in size, they're identical in design to the front brake calipers used on 5-Series models. **Note 2:** Some models may have different numbers and types of anti-squeal shims and other hardware than what is shown in this Chapter. It's best to note how the hardware is fitted on the vehicle before dismantling, so you can duplicate it on reassembly.



3.5a On 3-Series models, unscrew the caliper mounting bolts (left arrows); right arrows point to the caliper bracket bolts, which should only be removed if you're removing the brake disc



3.5b Unplug the electrical connector for the brake pad wear sensor (3-Series)



3.5c Hold the guide pins while loosening the caliper mounting bolts (3-Series)

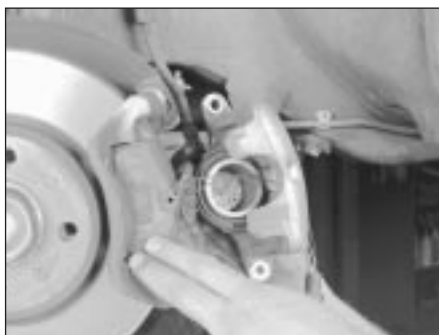

3.5d Remove the caliper, brake pad wear sensor and inner pad all at the same time (3-Series), then refit the inner pad on the piston and press the piston fully into the bore with a C-clamp



3.5e Remove the outer brake pad (3-Series) - to fit the new pads, reverse the removal procedure



3.5f On 5-Series models, unplug the electrical connector for the brake pad wear sensor

## 9•4 Braking system

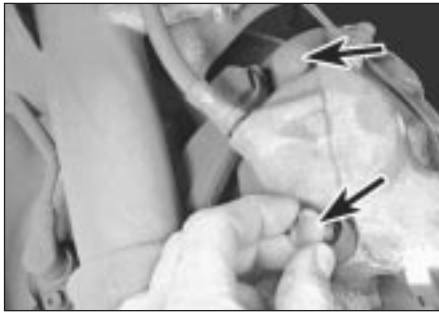

3.5g Remove the plugs for the brake caliper mounting bolts, then remove the bolts (5-Series)



3.5h Prise off the anti-rattle spring (5-Series)



3.5i Depress the piston with a C-clamp (5-Series)



3.5j Remove the caliper and inner brake pad (5-Series)



3.5k Unclip the inner brake pad from the piston (5-Series)



3.5l Hang the caliper out of the way with a piece of wire



3.5m Remove the outer brake pad - to fit the new pads, reverse the removal procedure

6 Be sure to inspect the wear sensor(s) (left front wheel only, or left front and right rear wheel). If they're OK, transfer them from the old pads to the new ones; if they're worn by abrasion, fit new sensors on the new pads.

7 To fit the new pads, reverse the removal procedure. When refitting the caliper, be sure to tighten the mounting bolts to the torque listed in this Chapter's Specifications.



**Warning:** Check and if necessary renew the mounting bolts on 3-Series models whenever they are removed. If in doubt, use new bolts.

8 After the job is completed, firmly depress the brake pedal a few times, to bring the pads into contact with the discs. The pedal should

be at normal height above the floor, and firm. Check the level of the brake fluid, adding some if necessary. Check carefully for leaks, and check the operation of the brakes before returning the vehicle to normal service.

9 Avoid heavy braking as far as possible for the first hundred miles or so until the new pads have bedded in.

### 4 Disc brake caliper - removal, overhaul and refitting



**Warning:** Dust created by the brake system may contain asbestos, which is harmful to your health. Never blow it out with compressed air, and don't inhale any of it. An approved filtering mask should be worn when working on the brakes. Do not, under any circumstances, use petroleum-based solvents to clean brake parts. Use brake system cleaner only!



**Warning:** Brake fluid is poisonous. It is also an effective paint stripper. Refer to the warning at the start of Section 16.

**Note:** If an overhaul is indicated (usually because of fluid leakage), explore all options before beginning the job. Overhauled calipers may be available on an exchange basis, which makes this job quite easy. If you decide to overhaul the calipers, make sure that an

overhaul kit is available before proceeding. Always overhaul the calipers in pairs - never overhaul just one of them.

### Removal

1 Loosen the wheel bolts, raise the front or rear of the vehicle, and place it securely on axle stands. Remove the wheel.

2 If you're just removing the caliper for access to other components, it isn't necessary to detach the brake line. If you're removing the caliper for overhaul, disconnect the brake line from the caliper, for preference using a split ring ("brake") spanner to protect the fitting. Plug the line, to keep contaminants out of the brake system and to prevent losing brake fluid unnecessarily.

3 Refer to Section 3 for the front or rear caliper removal procedure - it's part of the brake pad renewal procedure. **Note:** The rear caliper is similar in design to the front caliper on 5-series models.

### Overhaul

4 On all calipers except the front calipers on 3-Series models, remove the circlip for the dust seal (see illustration), then remove the dust boot (see illustration). Before you remove the piston, place a block of wood between the piston and caliper to prevent damage as it is removed.

5 To remove the piston from the caliper, apply compressed air to the brake fluid hose connection on the caliper body (see

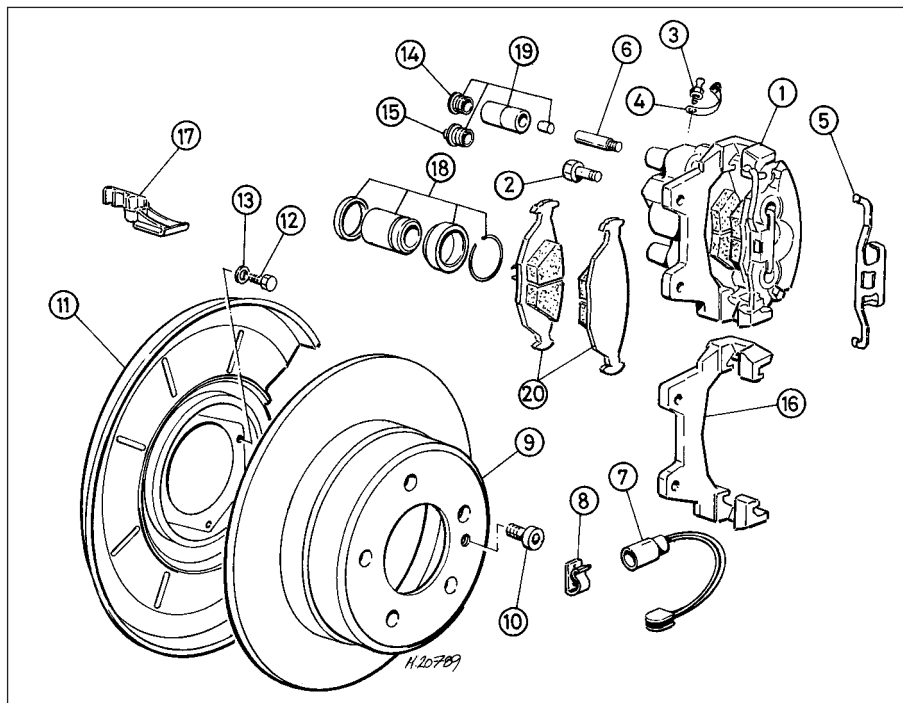

4.4a An exploded view of a typical rear caliper assembly (front calipers similar)

- |  |               |  |
|--|---------------|--|
| 1 Caliper assembly                     | 8 Cable clamp | 15 Plug                                    |
| 2 Bracket mounting bolt                | 9 Brake disc  | 16 Caliper bracket                         |
| 3 Bleed screw                          | 10 Allen bolt | 17 Cable clamp                             |
| 4 Dust cap                             | 11 Shield     | 18 Piston seal, piston<br>boot and circlip |
| 5 Anti-rattle spring                   | 12 Bolt       | 19 Guide bush repair kit                   |
| 6 Guide bolt                           | 13 Washer     | 20 Brake pads                              |
| 7 Brake pad wear warning<br>light wire | 14 Plug       |  |

**illustration).** Use only low pressure, such as that produced by a foot pump, to ease the piston out of its bore.

**Warning:** Be careful not to place your fingers between the piston and the caliper, as the piston may come out with some force. If you're working on a front caliper of a 3-Series model, remove the dust boot.

6 Inspect the mating surfaces of the piston and caliper bore wall. If there is any scoring, rust, pitting or bright areas, renew the complete caliper unit.

7 If these components are in good condition, remove the piston seal from the caliper bore using a wooden or plastic tool (see illustration). Metal tools may damage the cylinder bore.

8 Remove the caliper guide pins or bolts and remove the rubber dust boots.

9 Wash all the components using methylated spirit or brake system cleaner.

10 Using the correct overhaul kit for your vehicle, reassemble the caliper as follows.

11 Dip the new rubber seal in clean brake fluid, and refit it in the lower groove in the caliper bore, making sure it isn't twisted.

12 On all calipers except the front calipers of 3-Series models, coat the walls of the caliper

bore and the piston with clean brake fluid, and refit the piston at this time. Do not force the piston into the bore, but make sure that it is squarely in place, then apply firm (but not excessive) pressure to refit it. Fit the new rubber dust boot and the retaining ring.

13 On the front calipers of 3-Series models, coat the piston with clean brake fluid, and stretch the new dust boot over the bottom of the piston. Hold the piston over the caliper bore, and insert the rubber flange of the dust boot into the upper groove in the bore. Start with the furthest side from you, and work your way around towards the front until it is completely seated. Push the piston into the caliper bore until it is bottomed in the bore, then seat the top of the dust boot in the groove in the piston.

14 Lubricate the sliding surfaces of the guide pins or bolts with silicone-based grease (usually supplied in the kit), and push them into the caliper. Refit the dust boots.

### Refitting

15 Refit the caliper by reversing the removal procedure (see Section 3).

**Warning:** Check and if necessary renew the mounting bolts on 3-Series models whenever they are removed. If in doubt, use new bolts.



4.4b Remove the circlip for the dust seal



4.5 With the caliper padded to catch the piston, use low pressure compressed air to force the piston out of its bore - make sure your fingers are not between the piston and the caliper

16 If the hose was disconnected from the caliper, bleed the brake system (see Section 16).

## 5 Brake disc - inspection, removal and refitting

**Note:** This procedure applies to both the front and rear brake discs. Brake discs should always be renewed or refinished in pairs (both front or both rear discs) even if only one is damaged or defective.



4.7 Remove the piston seal from the caliper bore using a wooden or plastic tool (metal tools may damage the cylinder bore)

## 9•6 Braking system



5.2 Remove the caliper mounting bracket bolts (arrowed) and remove the bracket

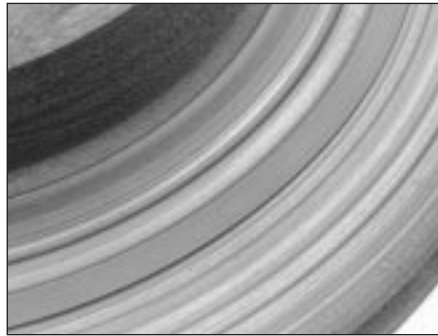

5.3 The brake pads on this vehicle were obviously neglected, as the backing plate cut deep grooves into the disc - wear this severe means the disc must be renewed



5.4a To check disc run-out, mount a dial indicator as shown, and rotate the disc

### Inspection

1 Loosen the wheel bolts, raise the vehicle and support it securely on axle stands. Remove the wheel, and refit three bolts to hold the disc in place. If the rear brake disc is being worked on, release the handbrake.

2 Remove the brake caliper as outlined in Section 4. It is not necessary to disconnect the brake hose. After removing the caliper, suspend it out of the way with a piece of wire. Remove the caliper mounting bracket (see illustration).

3 Inspect the disc surface for scoring, cracks or other damage. Light scratches and shallow grooves are normal after use, and are not usually detrimental to brake operation, but deep scoring requires disc removal and

renewal, or (if possible) refinishing by a specialist. If a disc is cracked it must be renewed. Be sure to check both sides of the disc (see illustration). If severe vibration has been noticed during application of the brakes, the discs may be warped (excessive run-out). If the vehicle is equipped with the Anti-lock Braking System (ABS), do not confuse vibration caused by warped discs with normal operation of the ABS. It is quite normal for some vibration to be felt through the pedal when the system is working.

4 To check disc run-out, place a dial indicator at a point about 13 mm from the outer edge of the disc (see illustration). Set the indicator to zero, and rotate the disc. The indicator reading should not exceed the specified

allowable run-out limit. If it does (and if the run-out is not due to wheel bearing wear), the disc should be renewed or (if possible) refinished by a specialist. **Note:** It is recommended that the discs be resurfaced regardless of the dial indicator reading, as this will impart a smooth finish and ensure a perfectly flat surface, eliminating any vibration felt through the brake pedal or other undesirable symptoms related to questionable discs. At the very least, if you elect not to have the discs resurfaced, remove the glazing from the surface with emery cloth or sandpaper, using a swirling motion (see illustration).

5 It is absolutely critical that the disc not be machined to a thickness less than that specified. The minimum wear (or discard) thickness is stamped into the hub of the disc. The disc thickness can be checked with a micrometer (see illustration).



5.4b Using a swirling motion, remove the glaze from the disc surface with sandpaper or emery cloth



5.5 The disc thickness can be checked with a micrometer



5.6a Remove the disc retaining screw . . .



5.6b . . . and remove the disc from the hub



5.6c If the disc is stuck to the hub, spray some penetrating oil onto the area between the hub and the disc, and give the oil a few minutes to separate the two parts



5.6d If a rear disc still sticks to the hub, insert a thin, flat-bladed screwdriver through the hub flange, rotate the starwheel on the handbrake adjusting screw, and contract the handbrake shoes (disc removed for clarity)

adjusting screw and contract the handbrake shoes (see illustration).

### HAYNES HiNT

If the front disc is stuck, on some discs it is possible to thread two or three bolts into the holes provided and tighten them. Alternate between the bolts, turning them a couple of turns at a time, until the disc is free.

## Refitting

7 Ensure that the disc is completely clean before refitting. If penetrating oil was used to remove the disc, make sure that no trace of this is present. Place the disc on the hub, and refit the disc retaining screw. Tighten the screw securely.

8 Refit the caliper mounting bracket (if removed), brake pads and caliper (see Sections 3 and 4). Tighten all fasteners to the torques listed in this Chapter's Specifications.

9 Refit the wheel, then lower the vehicle to the ground. Depress the brake pedal a few times to bring the brake pads into contact with the disc.

10 Adjust the handbrake shoes, if necessary (Section 11).

11 Check the operation of the brakes carefully before returning the vehicle to normal service.

## 6 Drum brake shoes - renewal



**Warning:** Brake shoes must be renewed on both wheels at the same time - never renew the shoes on only one wheel. Also, the dust created by the brake system may contain asbestos, which is harmful to your health. Never blow it out with compressed air, and don't inhale any of it. Always wear an approved filtering mask when servicing the brake system. Do not, under any

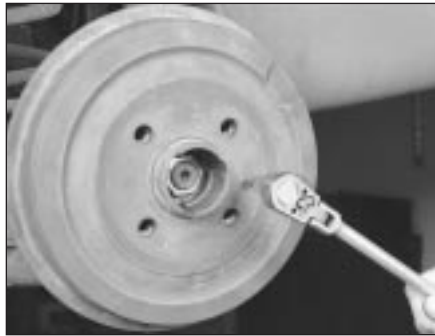

6.2a Removing the drum retaining screw

circumstances, use petroleum-based solvents to clean brake parts. Use brake system cleaner only.



**Caution:** Whenever the brake shoes are renewed, new return and hold-down springs and new automatic adjuster thermo-clips should also be fitted. Due to the continuous heating/cooling cycle to which the springs are subjected, they may lose their tension over a period of time, allowing the shoes to drag on the drum, and wear at a much faster rate than normal. When fitting new brake shoes, use only original-equipment or high-quality brand name parts.

**Note 1:** All four rear brake shoes must be renewed at the same time, but to avoid mixing up parts, work on only one brake assembly at a time. Some rear brake components are different for left and right-hand sides, so don't mix them up.

**Note 2:** If the wheel cylinder is found to be leaking or otherwise defective, renew it after removing the brake shoes. This is simply a matter of disconnecting the hydraulic line and unbolting the cylinder from the backplate. Attempting to overhaul a leaking cylinder is unlikely to be satisfactory, even if spare parts are available.

1 Chock the front wheels, then loosen the rear wheel bolts, raise the rear of the vehicle and place it securely on axle stands. Remove the rear wheels and release the handbrake.

2 Remove the drum retaining screw (see illustration) and remove the drum. If the drum is stuck to the hub, spray the area between the hub and the drum with penetrating oil (see illustration). If the drum still won't come off, the shoes have probably worn ridges into the drum, and will have to be retracted. Insert a narrow flat-bladed screwdriver through one of the holes in the hub flange (see illustration) and back off the adjuster wheel until the drum can be removed.

3 Inspect the drum for cracks, score marks, deep scratches and hard spots, which will appear as small discoloured areas. If the hard spots can't be removed with emery cloth or if any of the other conditions exist, the drum must be taken to a specialist to have the drum resurfaced. **Note:** Professionals recommend



6.2b If the drum is stuck to the hub, apply penetrating oil around the hub/drum area, and give it a few minutes to loosen up any rust



6.2c If the brake shoes have worn a groove in the drum and it won't come off, insert a thin flat-bladed screwdriver through one of the wheel bolt holes in the flange, and loosen the automatic adjuster mechanism (for the sake of clarity, the drum has already been removed in this photo, and the screwdriver is being inserted underneath the flange instead of through a wheel bolt hole)

resurfacing the drums whenever a brake job is done. Resurfacing will eliminate the possibility of out-of-round drums. If the drums are worn so much that they can't be resurfaced without exceeding the maximum allowable diameter (which is cast into the drum) (see illustration), then new ones will be required. At the very least, if you elect not to have the drums resurfaced, remove the glazing from the surface with emery cloth or sandpaper, using a swirling motion.



6.3 The maximum allowable inside diameter of the drum is cast into the drum

## 9•8 Braking system



6.4a Unhook the lower return spring from the front shoe . . .



6.4b . . . then unhook it from the rear shoe and remove it

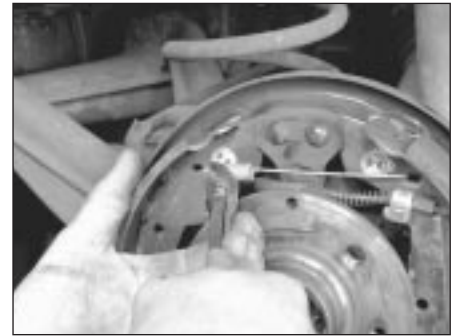

6.5a Unhook the upper return spring from the front shoe . . .



6.5b . . . then unhook it from the rear shoe and remove it



6.6a Remove the front shoe hold-down spring . . .



6.6b . . . and the rear shoe hold-down spring



6.7 Remove the front shoe, automatic adjuster lever and spring as an assembly, then remove the lever and spring, and set them aside for attachment to the new shoe



6.8 Remove the automatic adjuster assembly

4 Unhook and remove the lower return spring (see illustrations).

5 Unhook and remove the upper return spring (see illustrations).

6 Remove the front and rear brake shoe hold-down springs (see illustrations).

7 Remove the front shoe (see illustration).

8 Remove the adjuster assembly (see illustration). Clean the adjuster and make sure that the adjuster wheel moves freely on the threads. It is recommended that the thermo-clip (the spring clip next to the

adjuster wheel) be renewed whenever new shoes are fitted. Turn the adjuster wheel so that the assembly is at its shortest position ready for refitting.

9 Disconnect the handbrake cable from the handbrake lever, and remove the rear shoe (see illustration).

10 Refitting is basically the reverse of removal, but note the following points.

11 Apply a smear of high-temperature brake grease to the backing plate (see illustration). Be careful not to get grease onto the



6.9 To disconnect the handbrake cable from the handbrake lever, pull on the plug at the end of the cable, and detach the cable from the bracket on the upper end of the lever (diagonal cutting pliers are being used here because they grip the cable well, but care must be taken not to nick the cable)

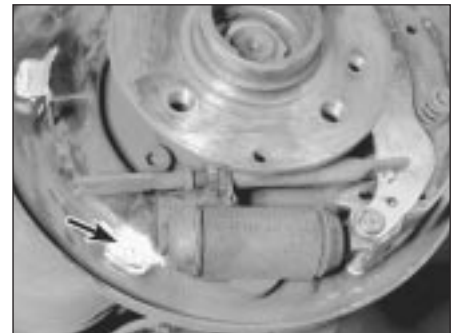

6.11 Before you fit the new shoes, apply some high-temperature brake grease to the friction surfaces where the inner edge of the shoe slides on the brake backing plate - when you refit the automatic adjuster mechanism, make sure each end engages properly with its respective notch in the brake shoe





**6.13a** Refit the automatic adjuster lever first - make sure it's properly engaged with the notch in the front end of the adjuster mechanism . . .



**6.13b** . . . then hook the lower end of the spring onto the lever as shown; stretch the spring, and hook the upper end into its hole in the handbrake shoe

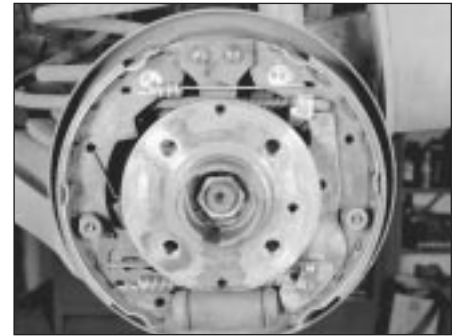

**6.14** When you get everything back together, this is how it should look!

friction surfaces of the brake shoes or drums.

**12** Make sure the adjuster assembly is properly engaged with its respective notch in the handbrake lever.

**13** When refitting the automatic adjustment mechanism, fit the lever on the shoe first (see illustration), then hook the lower end of the spring onto the lever and the upper end into its hole in the front shoe (see illustration).

**14** When you're done, the brake assembly should look like this (see illustration). Now proceed to the other brake.

**15** When you're done with both brakes, refit the brake drums.

**16** If the wheel cylinder was renewed (see Note 2), bleed the hydraulic system as described in Section 16.

**17** Depress the brake pedal repeatedly to actuate the self-adjusting mechanism. A clicking sound will be heard from the brake drums as the adjusters take up the slack.

**18** Check the handbrake adjustment (Section 11).

**19** Refit the wheels and bolts. Lower the vehicle to the ground, and tighten the wheel bolts to the torque listed in the Chapter 1 Specifications. Check the operation of the brakes carefully before driving the vehicle in traffic.

*can't be overhauled because of its internal condition.*

### Removal

**1** The master cylinder is connected to the brake vacuum servo, and both are attached to the bulkhead, located on the left-hand side of the engine compartment (see illustration).

**2** Remove as much fluid as you can from the reservoir with a syringe.

**3** Place rags under the line fittings, and prepare caps or plastic bags to cover the ends of the lines once they are disconnected.

**Caution:** Brake fluid will damage paint. Cover all body parts, and be careful not to spill fluid during this procedure.

**4** Loosen the union nuts at the ends of the brake lines where they enter the master cylinder. To prevent rounding off the flats on these nuts, a split ring ("brake") spanner, which wraps around the nut, should be used.

**5** Pull the brake lines away from the master cylinder slightly, and plug the ends to prevent dirt contamination and further fluid loss.

**6** Disconnect any electrical connectors at the master cylinder, then remove the nuts



**7.1** To remove the master cylinder, unplug the electrical connector (top arrow), disconnect the brake fluid hydraulic line fittings (lower right arrow, other fitting not visible in this photo) and remove the two master cylinder mounting nuts (lower left arrow, other nut not visible in this photo) - 5-Series master cylinder shown, 3-Series similar

attaching the master cylinder to the brake servo. Pull the master cylinder off the studs, and lift it out of the engine compartment. Again, be careful not to spill fluid as this is done. Discard the old O-ring (see illustration) between the master cylinder and the servo unit.

**Warning:** The O-ring should always be renewed. A faulty O-ring can cause a vacuum leak, which can reduce braking performance and cause an erratic idle.

### Bleeding procedure

**7** Before fitting a new or overhauled master cylinder, it should be bled on the bench. Because it will be necessary to apply pressure to the master cylinder piston and, at the same time, control flow from the brake line outlets, it is recommended that the master cylinder be mounted in a vice. Use a vice with protected jaws, and don't clamp the vice too tightly, or the master cylinder body might crack.

**8** Insert threaded plugs into the brake line outlet holes. Tighten them down so that there will be no air leakage past them, but not so tight that they cannot be easily loosened.

**9** Fill the reservoir with brake fluid of the recommended type (see "Lubricants, fluids and capacities" in Chapter 1).

**10** Remove one plug, and push the piston assembly into the master cylinder bore to

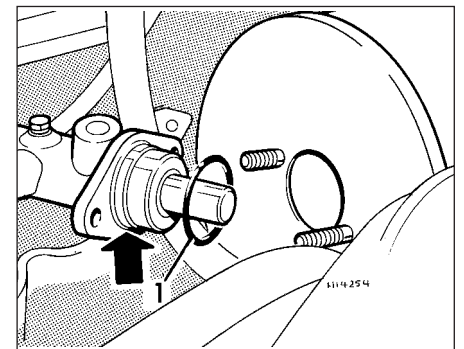

**7.6** Always renew the O-ring (1) - groove arrowed - between the master cylinder and the brake servo

## 7 Master cylinder - removal and refitting



**Warning:** Brake fluid is poisonous. It is also an effective paint stripper. Refer to the warning at the start of Section 16.

**Note:** Although master cylinder parts and overhaul kits are available for most models, we recommend fitting a new or overhauled master cylinder complete. It will take you more time to overhaul the master cylinder than to renew it, and you can't even determine whether the master cylinder is in good enough condition to overhaul it until you have dismantled it. You may very well find that it

## 9•10 Braking system

expel the air from the master cylinder. A large Phillips screwdriver can be used to push on the piston assembly.

**11** To prevent air from being drawn back into the master cylinder, the plug must be refitted and tightened down before releasing the pressure on the piston assembly.

**12** Repeat the procedure until brake fluid free of air bubbles is expelled from the brake line outlet hole. Repeat the procedure with the other outlet hole and plug. Be sure to keep the master cylinder reservoir filled with brake fluid, to prevent the introduction of air into the system.

**13** High pressure is not involved in the bench bleeding procedure, so the plugs described above need not be refitted each time the piston is released, if wished. Instead, before releasing the piston, simply put your finger tightly over the hole to keep air from being drawn back into the master cylinder. Wait several seconds for brake fluid to be drawn from the reservoir into the piston bore, then depress the piston again, removing your finger as brake fluid is expelled. Be sure to put your finger back over the hole each time before releasing the piston, and when the bleeding procedure is complete for that outlet, refit the plug and tighten it up before going on to the other port.

### Refitting

**14** Refit the master cylinder (together with a new O-ring) over the studs on the brake servo, and tighten the mounting nuts only finger-tight at this time.

**15** Thread the brake line fittings into the master cylinder. Since the master cylinder is still a bit loose, it can be moved slightly in order for the fittings to thread in easily. Do not strip the threads as the fittings are tightened.

**16** Tighten the brake fittings securely, and the mounting nuts to the torque listed in this Chapter's Specifications.

**17** Fill the master cylinder reservoir with fluid, then bleed the master cylinder (only if the cylinder has not already been bled) and the brake system as described in Section 16.

**18** To bleed the cylinder on the vehicle, have an assistant pump the brake pedal several

times and then hold the pedal to the floor. Loosen the fitting nut to allow air and fluid to escape, then tighten the nut. Repeat this procedure on both fittings until the fluid is clear of air bubbles. Test the operation of the brake system carefully before returning the vehicle to normal service.

### 8 Brake vacuum servo - check, removal and refitting



#### Operating check

**1** Depress the brake pedal several times with the engine off, until there is no change in the pedal travel.

**2** Depress and hold the pedal, then start the engine. If the pedal goes down slightly, operation is normal.

#### Airtightness check

**3** Start the engine, and turn it off after one or two minutes. Depress the brake pedal several times slowly. If the pedal goes down further the first time but gradually rises after the second or third depression, the servo is airtight.

**4** Depress the brake pedal while the engine is running, then stop the engine with the pedal depressed. If there is no change in the pedal travel after holding the pedal for 30 seconds, the servo is airtight.

#### Removal and refitting

**5** Dismantling the vacuum servo requires special tools, and cannot be performed by the home mechanic. If a problem develops, it is recommended that a new unit be fitted.

**6** Remove the master cylinder as described in Section 7.

**7** Disconnect the vacuum hose from the brake servo.

**8** Working in the passenger compartment, remove the glovebox and lower left-hand trim panels.

**9** Remove the clip and clevis pin to disconnect the pushrod from the cross-shaft lever (right-hand-drive models) or brake pedal



**8.9** Disconnect the brake pedal return spring, then remove the clip and clevis pin (arrows) to disconnect the pushrod from the brake pedal (left-hand-drive models)

(left-hand-drive models) (see illustration). On left-hand-drive models, also disconnect the brake pedal return spring.

**10** Remove the four mounting nuts (see illustration) and withdraw the servo unit from the engine compartment.

**11** Inspect the small foam filter (see illustration) inside the rubber boot on the pushrod. If the filter is clogged, it may affect the servo's performance. To clean the filter, wash it in a mild soapy solution. If it's still dirty, renew it.

**12** Refitting is the reverse of the removal procedure. Tighten the brake servo mounting nuts to the torque listed in this Chapter's Specifications. Before you slide the boot into place over the servo pushrod air filter, make sure the notches in the filter offset the notches in the damper by 180 degrees.

**13** On 3-Series models, adjust the basic setting of the pushrod's threaded clevis until the dimension is correct (see illustration). When the basic setting is correct, tighten the locknut, then adjust the brake pedal travel and

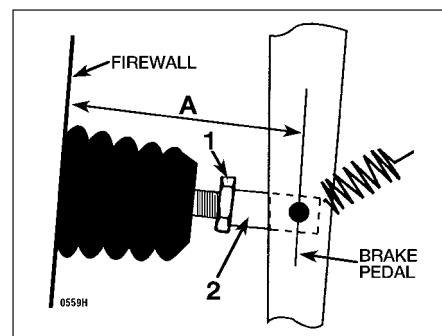

**8.13** On 3-Series models, adjust dimension A (the distance between the middle of the brake lever and the bulkhead/"firewall") by loosening the locknut (1) at the pushrod clevis (2) and turning the threaded part of the pushrod until dimension A matches the dimension listed in this Chapter's Specifications. When the basic setting is correct, tighten the locknut, then adjust the brake pedal height and the stop-light switch



**8.10** Remove the four mounting nuts (arrows) and withdraw the servo unit from the engine compartment (left-hand-drive model shown)

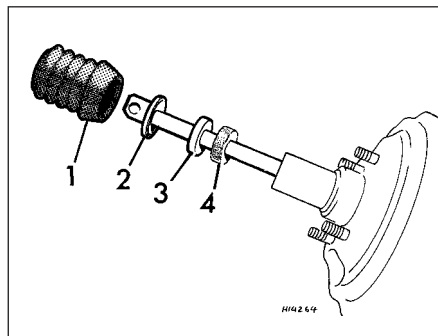

**8.11** An exploded view of a typical servo pushrod assembly

1 Boot 2 Holder 3 Damper 4 Air filter

the stop-light switch (see Section 13). **Note:** *On right-hand-drive models, the brake pedal in on the right-hand side of the vehicle, and is connected to the left-hand side by a cross-shaft. The adjustment is carried out on the pushrod at the left-hand side, but the dimension is measured at the pedal on the right-hand side.*

**14** On 5-Series models, adjust the brake pedal height and the stop-light switch (see Section 13).

**15** Refit the master cylinder (see Section 7) and attach the vacuum hose.

**16** Carefully test the operation of the brakes before returning the vehicle to normal use

## 9 Hydraulic brake servo - description, removal and refitting



**Warning:** *Brake fluid is poisonous. It is also an effective paint stripper. Refer to the warning at the start of Section 16.*

### Description

**1** On 5-Series E28 ("old-shape") models, a hydraulic brake servo system is fitted. The servo unit, located between the brake pedal (left-hand-drive) or cross-shaft lever (right-hand-drive) and the master cylinder, is operated by hydraulic pressure generated by the power steering pump. When the engine is running, the power steering pump supplies hydraulic pressure to a power flow regulator/accumulator. The regulator/accumulator stores and regulates the pressure to the hydraulic brake servo. When you press the brake pedal, the pressure in the servo helps actuate the master cylinder, reducing pedal effort.

**2** The hydraulic brake servo cannot be overhauled; if it fails, a new one must be fitted. Testing the system requires special tools, so even fault diagnosis is beyond the scope of the home mechanic. If the system fails, take it to a dealer service department or other qualified garage for repairs.

### Removal and refitting

**3** With the engine off, discharge the hydraulic accumulator by depressing the brake pedal 20 times or more.

**4** Remove the master cylinder (see Section 7).

**5** Clean the area around the return and supply line fittings, then disconnect them. Plug the lines, to prevent dirt from entering the system, and to prevent further fluid loss.



**Caution:** *Even a particle of dirt can damage the servo, so be extremely careful to prevent dirt from entering the system while the lines are disconnected.*

**6** Working from inside the passenger compartment, remove the lower left trim panels above the brake pedal (left-hand-drive models) or glovebox and trim (right-hand-

drive models). On left-hand-drive models, also disconnect the pedal return spring.

**7** Prise off the retaining clip, and disconnect the pushrod from the brake pedal (see illustration 8.9) or cross-shaft lever.

**8** Remove the four mounting nuts and remove the brake servo (see illustration 8.10).

**9** Refitting is the reverse of removal. Tighten the hydraulic lines to the torque listed in this Chapter's Specifications. **Note:** *Don't try to tighten these fittings without a torque wrench. If they're loose, they can leak, which can affect system operation; if they're tight, they can be damaged, and they'll also leak. You'll need a crowfoot-type split ring ("brake") attachment for your torque wrench to tighten the fittings properly.*

**10** When you're done, bleed the brake hydraulic system (Section 16) and adjust the brake pedal travel and the stop-light switch (see Section 13).

## 10 Handbrake cable(s) - renewal



**1** Peel back the boot at the base of the handbrake lever, and remove the handbrake cable adjusting nut (see illustration) which also secures the cable to the handbrake lever.



**10.1** Peel back the handbrake lever boot and remove the relevant handbrake cable adjusting nut (both arrowed)



**10.4a** To detach the handbrake cable from the handbrake actuator on models with rear disc brakes, pull on the outer cam and disconnect it from the inner cam . . .



**10.4b** . . . then remove the pin securing the cable to the inner cam, and remove the inner cam



**10.6** Pull the cable out of its conduit; before you refit the new cable, be sure to lubricate it with multi-purpose grease

There are two cables - one for each rear wheel - and a nut for each cable. On some models, it may be necessary to remove the centre console completely for access.

**2** Raise the vehicle and support it securely on axle stands.

**3** Remove the rear brake drum (see Section 6) or rear brake disc (see Section 5).

**4** On rear drum models, unhook the handbrake cable from the lever on the rear brake shoe (see Section 6). On rear disc models, remove the handbrake shoes and the actuator (see Section 12) and unhook the handbrake cable from the actuator (see illustrations).

**5** On rear drum models, pull the cable and cable conduit (tube) out of the back of the brake backplate, then detach the cable conduit from the cable clips on the back of the trailing arm (it's easier to pull out the old cable, and fit the new cable, with the conduit straight instead of curved). On rear disc models, it's unnecessary to detach the cable conduit from the brake backplate, but it's a good idea to detach the conduit from the clips and guides securing it to the trailing arm, to take some of the bend out of the conduit.

**6** Working from the wheel end of the cable conduit, pull the cable out of the conduit (see illustration).

**7** Lubricate the new cable with multi-purpose grease, then insert it into the cable conduit

## 9•12 Braking system

and push it through until the forward end comes out at the handbrake lever.

**8** Insert the cable conduit through the backplate, and attach the rear end of the cable to the handbrake lever (rear drum models) or the actuator (rear disc models). Make sure you don't kink the cable while connecting it.

**9** Refit the cable conduit to the clips on the back of the trailing arm.

**10** On rear drum models, refit the brake shoes and drum (see Section 6). On rear disc models, refit the handbrake shoes and actuator (see Section 12) and the rear brake disc (see Section 5).

**11** Lower the vehicle, and refit the adjusting nut at the handbrake lever. Adjust the handbrake cable (see Section 11) and refit the handbrake lever boot.

### 11 Handbrake - adjustment



#### Rear drum brake models

**Note:** Adjustment of the handbrake cable(s) on models with rear drum brakes should only be necessary when you renew a cable or detach it from the rear brake assembly for some reason. Failure of the handbrake system to hold the vehicle usually indicates worn brake shoes or a faulty self-adjusting mechanism.

**1** Raise the rear of the vehicle, and place it securely on axle stands.

**2** Fully release the handbrake lever, then apply the brakes firmly several times with the footbrake pedal.

**3** Pull the handbrake lever up five clicks.

**4** Tighten or loosen the adjusting nuts by equal amounts until the rear brake shoes just begin to drag on the brake drum. You should feel the same amount of resistance at both wheels when you rotate them.

**5** Release the handbrake lever, and verify that the wheels rotate freely. If they don't, re-adjust them.

#### Rear disc brake models

**Note:** The handbrake system is not self-adjusting on models with rear disc brakes. The handbrake therefore requires periodic adjustment to compensate for wear. It should also be adjusted anytime either cable, brake disc or handbrake assembly is renewed or removed for some reason.

**6** Slowly apply the handbrake, and count the number of clicks at the lever. If the lever can be pulled up further than the eighth click, adjust the handbrake cable as follows.

**7** Peel back the handbrake lever boot, and loosen the cable adjusting nut (see illustration 10.1). On some models, it may be necessary to remove the centre console completely for access.

**8** Loosen a single bolt in each rear wheel.

Raise the vehicle and place it securely on axle stands.

**9** Remove the bolt you loosened in each rear wheel. Turn the wheel until, using a torch, you can see the adjuster starwheel through the bolt hole.

**10** Turn the adjuster - clockwise to expand the shoes, anti-clockwise to retract them - until the brake shoes just contact the brake drum (see illustration 5.6d). Back off the brake shoes so the wheel spins freely (three to four teeth on the adjuster). **Note:** If the adjuster starwheel is hard to turn, remove the wheel and brake disc, lubricate the adjuster wheel, and try again.

**11** With the disc fitted, apply the handbrake three times to stretch and seat the cables, then slowly pull up on the handbrake lever to the fifth click. Tighten the cable adjusting nuts by equal amounts until the rear brake shoes just touch the brake drum. Verify that both wheels have the same amount of resistance.

**12** Release the handbrake, and verify that both rear wheels rotate freely.

**13** Tighten the wheel bolts to the torque listed in Chapter 1 Specifications.

### 12 Handbrake assembly - check, removal and refitting



**Warning:** The handbrake linings on rear disc brake models may be manufactured of asbestos-based material. Refer to the

warning at the start of Section 6. When servicing these components, do not create dust by grinding or sanding the linings.

**1** The handbrake system should be checked regularly. With the vehicle parked on a hill, apply the handbrake, select neutral, and check that the handbrake alone will hold the vehicle when the footbrake is released (be sure to stay in the vehicle during this check). However, every 2 years (or whenever a fault is suspected), the assembly itself should be inspected.

**2** With the vehicle raised and supported on

axle stands, remove the rear wheels.

**3** On rear brake drum models, refer to Chapter 1; checking the thickness of the brake shoes is a routine maintenance procedure.

**4** On rear disc brake models, remove the rear discs as outlined in Section 5. Support the caliper assemblies with a coat hanger or heavy wire; do not disconnect the brake line from the caliper.

**5** With the disc removed, the handbrake components are visible, and can be inspected for wear and damage. The linings should last the life of the vehicle. However, they can wear down if the handbrake system has been improperly adjusted, or if the handbrake is regularly used to stop the vehicle. There is no minimum thickness specification for the handbrake shoes, but as a rule of thumb, if the shoe material is less than 1.5 mm thick, you should renew them. Also check the springs and adjuster mechanism and inspect the drum for deep scratches and other damage.

#### Removal and refitting

**Note:** The following procedure applies only to models with rear disc brakes. The handbrake system on models with rear drum brakes is an integral part of the rear brake assembly (see Section 6).

**6** Loosen the rear wheel bolts, raise the rear of the vehicle and place it securely on axle stands. Remove the rear wheels. Remove the brake discs (see Section 5). Work on only one side at a time, so you can use the other side as a reference during reassembly, and to avoid mixing up parts.

**7** Remove the shoe return and hold-down springs (see illustrations).

**8** Remove the shoes (see illustration).

**9** Refitting is the reverse of removal. When you're done, the actuator should be properly seated between the two shoes as shown (see illustration).

**10** After refitting the brake disc, adjust the handbrake shoes. Temporarily refit two wheel bolts, turn the adjuster (see illustration 5.6d) and expand the shoes until the disc locks,



12.7a Remove the lower shoe return spring (diagonal cutting pliers are being used here because they grip the spring well, but care must be taken not to cut or nick the spring)



12.7b Remove the upper shoe return spring



12.7c Remove the shoe hold-down springs



12.8 Remove the shoes



12.9 When you're done, the actuator should be properly seated between the two shoes as shown (hub removed for clarity)

then back off the adjuster until the shoes don't drag (see Section 11). Refit the wheel bolts, and tighten them to the torque given in Chapter 1 Specifications.

### 13 Brake pedal - adjustment



**Note:** You should always adjust brake pedal height after the master cylinder or brake servo has been removed or renewed. You should also adjust the stop-light switch (see Section 14).

1 Measure the distance between the lower edge of the brake pedal footpad (ie the edge furthest from the bulkhead) and the bulkhead (see illustration), and compare your measurement with the dimension listed in this Chapter's Specifications. If it's not as listed, loosen the locknut on the pushrod, and rotate

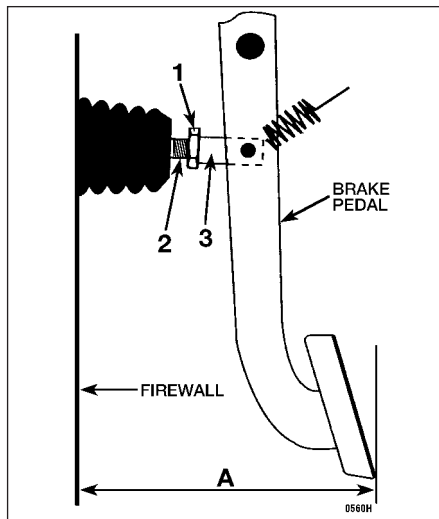

13.1 To adjust the brake pedal height, loosen the locknut (1) and turn the pushrod (2) while holding the clevis (3) until dimension A (the distance between the lower edge of the brake pedal and the bulkhead/"firewall") is within the range listed in this Chapter's Specifications (left-hand-drive shown, right-hand-drive similar)

the pushrod while holding the clevis stationary until the distance is correct. **Note:** On right-hand-drive models, the adjustment is carried out at the left-hand side of the cross-shaft, after removing the glovebox, but the dimension is still measured at the pedal.

### 14 Stop-light switch - check and adjustment



**Note:** The stop-light switch should be checked and, if necessary, adjusted after the master cylinder or brake servo has been removed or renewed.

1 The stop-light switch is located on a bracket at the top of the brake pedal. The switch activates the brake lights whenever the pedal is depressed.

2 With the brake pedal in the rest position, measure the distance between the switch contact point on the brake pedal and the switch housing (see illustration) and compare your measurement with dimension A listed in this Chapter's Specifications.

3 If your measurement is outside the

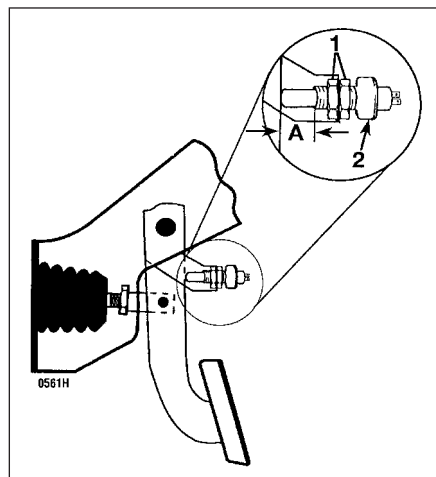

14.2 To adjust the stop-light switch, loosen the locknuts (1) and screw the switch (2) in or out until dimension A is correct

indicated dimension, disconnect the wires from the switch. Loosen the locknuts, screw the switch in or out until the plunger dimension is correct, and retighten the locknuts. Reconnect the wires and check for correct operation.

### 15 Brake hoses and lines - inspection and renewal



**Warning:** Brake fluid is poisonous. It is also an effective paint stripper. Refer to the warning at the start of Section 16.

#### Inspection

1 At the intervals specified in Chapter 1, the brake hoses and lines should be inspected. With the vehicle raised and placed securely on axle stands, the flexible hoses should be checked for cracks, chafing of the outer cover, leaks, blisters and other damage. These are important and vulnerable parts of the brake system, and inspection should be thorough. The metal pipes should be checked for excessive pitting and corrosion. If a hose or pipe exhibits any of the conditions described, renew it.



A torch and mirror will prove helpful for a complete hose and line check.

#### Flexible hose renewal

2 Clean all dirt away from the ends of the hose. Have ready a suitable container to catch spilled brake fluid when the hose is disconnected.

3 To disconnect the hose at the chassis end, use a spanner to hold the hex-shaped fitting on the end of the flexible hose, and loosen the nut on the metal brake line (see illustration). If the nut is stuck, soak it with penetrating oil. After the hose is disconnected from the metal line, remove the spring clip from the bracket and detach the hose from the bracket.

4 To detach the flexible hose from the caliper,



**15.3** A typical brake line-to-brake hose connection: To disconnect it, use one spanner to hold the hex-shaped fitting on the end of the flexible hose (lower right arrow) and loosen the threaded fitting on the metal line with a split ring ("brake") spanner (upper right arrow), then remove the spring clip (left arrow)

simply unscrew it. Plug the open fitting in the caliper if the hose is removed for any length of time, to prevent dirt ingress.

**5** Refitting is the reverse of the removal procedure. Make sure the brackets are in good condition and the locknuts are securely tightened. Renew the spring clips if they don't fit tightly.

**6** Carefully check to make sure the suspension and steering components do not make contact with the hoses. Have an assistant turn the steering wheel from lock-to-lock during inspection.

**7** Bleed the brake system as described in Section 16.

### Metal brake line renewal

**8** When renewing brake lines, use genuine parts only - preferably from a BMW dealer.

**9** Genuine BMW brake lines are supplied straight. You'll need a pipe-bending tool to bend them to the proper shape.

**10** First, remove the line you intend to renew, lay it on a clean workbench and measure it carefully. Obtain a new line of the same length, and bend it to match the pattern of the old line.



**Warning:** Do not crimp or damage the line. No bend should have a smaller radius than

**14 mm.** Make sure the protective coating on the new line is undamaged at the bends.

**11** When fitting the new line, make sure it's well supported by the brackets, that the routing matches the original, and that there's plenty of clearance between movable components or those components which will become hot.

**12** After refitting, check the master cylinder fluid level, and add fluid as necessary. Bleed the brake system as outlined in Section 16, and test the brakes carefully before driving the vehicle. Be sure there are no leaks.

## 16 Brake hydraulic system - bleeding



**Warning:** Wear eye protection when bleeding the brake system. If the fluid comes in contact with your eyes, immediately rinse them with water, and seek medical attention. Most types of brake fluid are highly flammable, and may ignite if spilled onto hot engine components, for example. In this respect, brake fluid should be treated with as much care as if it were petrol. When topping-up or renewing the fluid, always use the recommended type, and ensure that it comes from a freshly-opened sealed container. Never re-use old brake fluid bled from the system, and don't top-up with fluid which has been standing open for a long time, as it is potentially dangerous to do so.



**Brake fluid is an effective paint stripper, and will attack plastics; if any is spilt, wash it off immediately with copious amounts of water.**

**Note:** Bleeding the hydraulic system is necessary to remove any air which has entered the system during removal and refitting of a hose, line, caliper or master cylinder.

**1** It will probably be necessary to bleed the system at all four brakes if air has entered the system due to low fluid level, or if the brake lines have been disconnected at the master cylinder.

**2** If a brake line was disconnected at only one wheel, then only that caliper or wheel cylinder need be bled.

**3** If a brake line is disconnected at a fitting located between the master cylinder and any of the brakes, that part of the system served by the disconnected line must be bled.

**4** Bleed the right rear, the left rear, the right front and the left front brake, in that order, when the entire system is involved.

**5** Remove any residual vacuum from the brake servo by applying the brakes about 30 times with the engine off. This will also relieve any pressure in the anti-lock brake system (where applicable).

**6** Remove the master cylinder reservoir cover, and fill the reservoir with brake fluid. Refit the cover. **Note:** Check the fluid level often during the bleeding operation, and add fluid as necessary to prevent the fluid level from falling low enough to allow air into the master cylinder.

**7** Have an assistant on hand, an empty clear plastic container, and a length of clear plastic or vinyl tubing to fit over the bleed screws. Alternatively, a "one-man" bleeding kit can be used. A "one-man" kit usually contains a tube

or bottle with a one-way valve incorporated - in this way, the pedal can be pumped as normal, but air is not drawn back into the system when the pedal is released. If a one-man kit is used, follow the instructions provided with it; similarly with pressure bleeding kits. In any case, you will also need a supply of new brake fluid of the recommended type, and a spanner for the bleed screw.

**8** Beginning at the right rear wheel, loosen the bleed screw slightly, then tighten it to a point where it is tight but can still be loosened quickly and easily.

**9** Place one end of the tubing over the bleed nipple, and submerge the other end in brake fluid in the container (see illustration).

**10** Have the assistant pump the brakes a few times, then hold the pedal firmly depressed.

**Note:** If the vehicle is equipped with ABS, have the assistant pump the pedal at least 12 times.

**11** While the pedal is held depressed, open the bleed screw just enough to allow a flow of fluid to leave the caliper or wheel cylinder. Your assistant should press the brake pedal smoothly to the floor, and hold it there. Watch for air bubbles coming out of the submerged end of the tube. When the fluid flow slows after a couple of seconds, close the screw and have your assistant release the pedal.

**12** Repeat paragraphs 10 and 11 until no more air is seen leaving the tube, then tighten the bleed screw and proceed to the left rear wheel, the right front wheel and the left front wheel, in that order, and perform the same procedure. Be sure to check the fluid in the master cylinder reservoir frequently.



**Warning:** Never re-use old brake fluid. It absorbs moisture from the atmosphere, which can allow the fluid to boil and render the brakes inoperative.

**13** Refill the master cylinder with fluid at the end of the operation.

**14** Check the operation of the brakes. The pedal should feel solid when depressed, with no sponginess. If necessary, repeat the entire process. Do not operate the vehicle if you are in doubt about the effectiveness of the brake system.

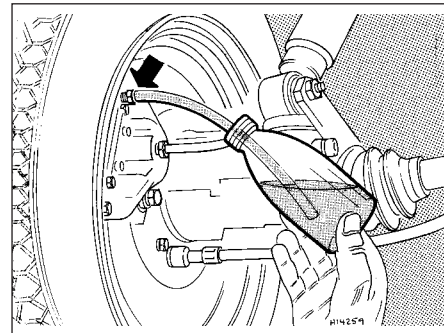

**16.9** Place one end of the tubing over the bleed screw, and submerge the other end in brake fluid in the container